



Kilpatrick

Counsel to
innovative
businesses
and brands

Kilpatrick is trusted counsel to the world's most innovative companies. As one of a handful of law firms focused on serving the most groundbreaking companies, we always strive to be at the forefront, from creating a best-in-class client experience; to fostering diversity, equity, and inclusion; to proactively addressing challenges and seizing opportunities on the cutting edge of law and technology.

We do things differently from our peers because we put people first. Our highly skilled and intellectually curious team delivers practical, business-centric solutions built upon unusually strong and enduring connections with our clients and collaboration with each other. With a foundation of more than 160 years of success, we are steadfastly future-focused, driving innovation while cultivating genuine relationships. We are optimistic about the future and invest in the success of our clients, our people, and our communities.

22

offices in the U.S. and internationally in Stockholm, Tokyo, Shanghai, and Beijing

1/3

of Fortune 50 companies turn to Kilpatrick for trusted counsel

126

Tier 1 National and Metropolitan Practices recognized in the 2024 Edition of *Best Law Firms*®

National Trademark Practice was awarded

Gold-level Ranking

the highest tier available, by the 2024 *World Trademark Review (WTR) 1000*, the World's Leading Trademark Professionals



Kilpatrick Townsend & Stockton is an outstanding firm. They're best known for their intellectual property expertise, but they have a very robust banking transactional practice, including significant M&A expertise. I have found that for most M&A transactions, they're every bit as good as some of the best-known Wall Street firms but at a much lower cost."

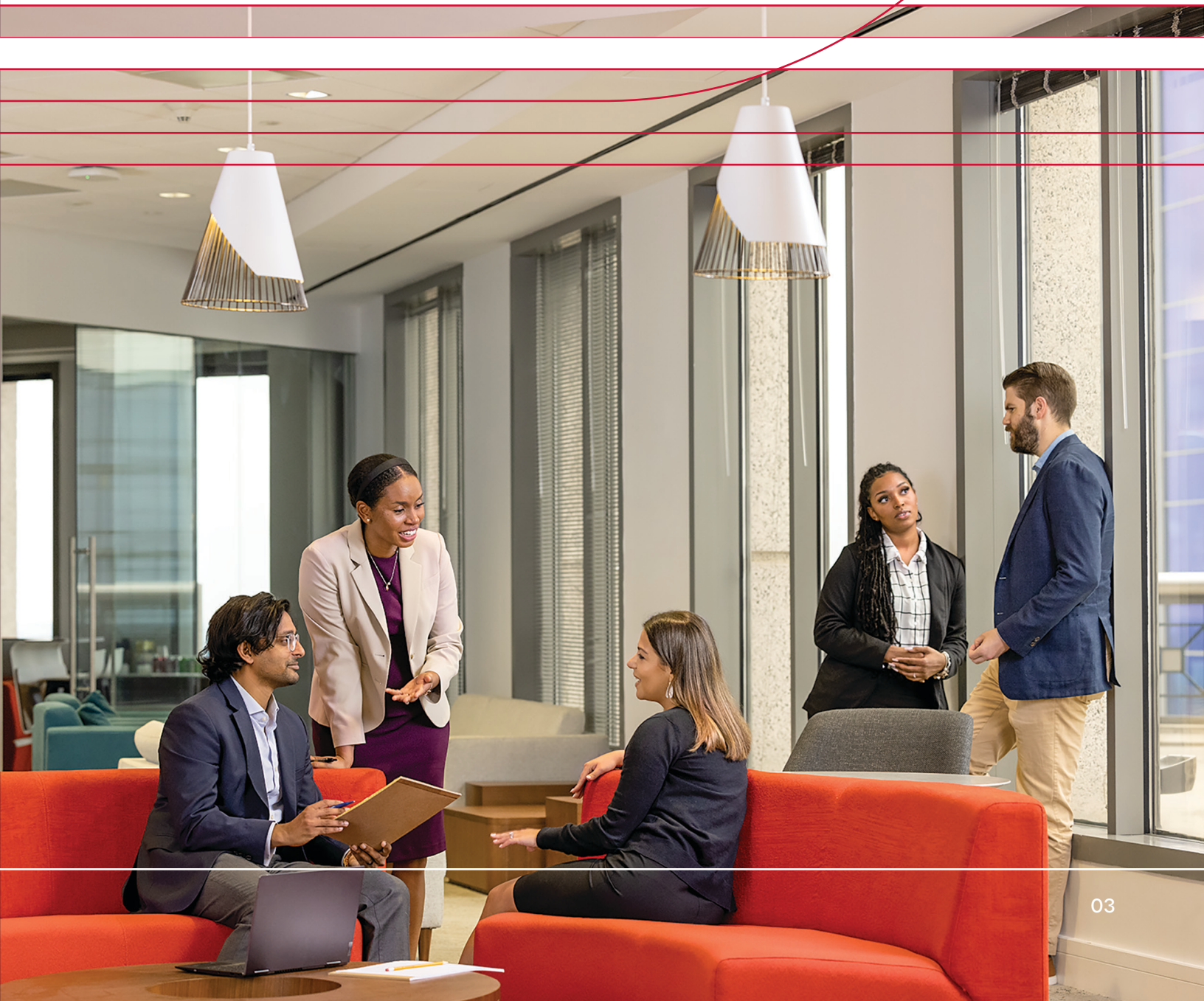

Our services

Kilpatrick is proactive, scanning the horizon for challenges and opportunities, and we solve problems before they arise. Clients trust our experience, legal acumen, and business savvy, but more than that, they appreciate our distinctive understanding of their businesses and the close, personal relationships we forge with them.

2024 Annual Managing
IP Awards:

IP Firm of the
Year for the
Americas for the
second time in three years.

U.S.
Trademark
Prosecution
Firm of the
Year for the third year
in a row and sixth time
overall.

Business & Finance

Our experience covers a wide spectrum of key business and finance matters. We handle contracts and commercial agreements, corporate governance, mergers and acquisitions, private equity, securities, real estate finance and capital markets, economic development, emerging companies, and franchising.

Intellectual Property

With more than 300 attorneys dedicated to patent, trademark, copyright, advertising, and/or trade secrets law, we boast all the expertise of a self-sufficient IP practice backed by the resources and business acumen of a full-service law firm. Our attorneys offer comprehensive registration, transactional, and litigation services when helping clients create, build, and protect their most valuable assets – their brands.

Litigation

Our litigators explore every available avenue to resolve critical business disputes. We seek to establish relationships for the long term, employing litigation strategies driven by your business imperatives. Our practice specialties cover the entire range of complex business disputes, from construction and infrastructure to employment, environmental, and class action litigation.

Bankruptcy & Financial Restructuring

Serving routinely as bankruptcy counsel in national cases, our team is recognized for its ability to negotiate and structure realistic business resolutions for complex and arduous proceedings both in and out of court.

Construction & Infrastructure

With more than 40 attorneys focused on construction and government contracts law, we bring decades of experience



in all types of construction-related legal matters – planning, permitting, financing, environmental compliance, negotiating, contract review and drafting, claim preparation, management and evaluation, dispute avoidance and resolution, insurance coverage, and litigation.

Cybersecurity, Privacy & Data Governance

We help clients protect their sensitive information in the most pragmatic, cost-effective, business-focused way possible. Our Cybersecurity, Privacy & Data Governance practice takes a comprehensive, multidisciplinary, and integrated approach to protect and help our clients with risk management, response, disputes, investigations, and recoveries.

Employee Benefits

We offer consultation on executive and benefit plan design in keeping with regulatory demands. From a transactional perspective, we evaluate benefit programs and advise on

strategies to contain costs, limit liability, and protect benefits during the course of a merger or acquisition. We also represent clients facing government and private party litigation and state and federal agency adjudicatory proceedings.

Government & Regulatory

Our interdisciplinary team of attorneys works to keep clients aware of legislative developments and represents them in negotiations and hearings before regulatory bodies. We also have the government experience to ably advocate when court challenges are necessary.

Labor & Employment

Our team helps clients navigate labor and employment regulations that are in a constant state of flux and require adaptive responses. We also assist with classifying employees within unconventional business models; take steps to increase diversity and avoid discrimination; maintain stringent safety standards; and successfully

counter class action and individual plaintiff litigation.

Native American Affairs

Our Native American Affairs Practice Group has earned a national reputation for preserving, promoting, and protecting tribal sovereignty. Our team consists of enrolled members and descendants of federally recognized tribes, former tribal in-house counsel, and experienced litigators who are dedicated to empowering tribal governments.

Technology Transactions

As opportunities to buy and sell goods expand and innovative technologies become more accessible, our team offers the means to achieve greater cost control and improve efficiencies. By implementing digital and data-driven strategies through technology transactions and complex relationship management, we successfully serve buyers, users, sellers, and providers in a variety of onshore, nearshore, and offshore complex business transactions.

Law Firm of the Year

Litigation – Intellectual Property
2024 Edition of Best Law Firms®

17

Band 1,
Star Individuals,
or Eminent
Practitioner
rankings

Chambers USA 2024

264

Kilpatrick attorneys have recently been honored by their peers in the 2024 editions of *The Best Lawyers in America*® and *Best Lawyers: Ones to Watch in America*

COUNSEL TO INNOVATORS

Industry focus

Agribusiness / Food Tech

In today's increasingly complex and technology-focused agribusiness and food industry landscape, innovative businesses partner with Kilpatrick to help build value and acquire a competitive edge. We represent a broad range of clients engaged in traditional farming and plant technology, animal health, food sciences, food producers and brands, supply chain logistics, energy, and finance.

Energy

Our Energy team serves innovative clean energy industry clients, who develop and finance solar, biomass, clean fuels, and energy storage projects, while also helping energy users implement sustainable energy programs and practices. We provide our clients with the pragmatic counsel required to handle all aspects of project development and finance, energy investments, and energy procurement.

Financial Services

Over the course of four decades, our Financial Services team has built a national reputation and counseled hundreds of banking and financial institutions on a wide variety of transactional and regulatory matters. We balance commercial considerations with strict compliance and a goal to minimize risk where possible.

Health & Life Sciences

Leveraging our integrated approach and years of unprecedented experience, our Health & Life Sciences team partners with clients in all sectors of health and life sciences to provide legal and business solutions involving transactional matters, regulatory compliance, and all aspects of dispute resolution worldwide.

5

of the top 10 world's most valuable brands turn to Kilpatrick to grow and defend the value of their products and businesses

10

of the top 25 largest financial institutions apply capital, manage regulations, and meet market demands with Kilpatrick at their side

Media & Entertainment

We have a long history of providing counsel to major digital media and entertainment brands across a full spectrum of industry issues and multiple jurisdictions. We utilize our legal acumen and extensive industry knowledge to help clients develop innovative strategies that engage, grow, and monetize their customers; mitigate risks; and capitalize on evolving market trends.

Retail & Consumer Goods

With a deep understanding of many diverse business environments, our multidisciplinary attorneys help clients meet the demands of consumers, suppliers, and investors. Our clients operate both online and in brick-and-mortar stores, while manufacturing and selling goods in a variety of sectors, including: Apparel, Accessories & Luxury Goods; Automotive; Consumer Goods & Electronics; Food, Restaurant & Beverage; and Home Furnishings.

Technology

For more than a century, we have been a pioneer in the field and continue to offer technology clients proactive, business-oriented counsel and cutting-edge legal solutions. Our attorneys provide counsel on enhancing and evolving businesses through financing, joint ventures, strategic alliances, and sales and acquisitions. We also ably represent technology clients in litigation and patent disputes.





*We picked the firm because of their litigation skills.
We wanted people who were fighters and they were
amazing at the trial level.”*



Our client service principles

Innovation requires courage. The world's most trailblazing organizations count on Kilpatrick not only for practical, business-savvy solutions to today's issues, but also for our creativity and ability to foresee and move on tomorrow's challenges and opportunities. We share our clients' passion, enthusiasm, and sense of possibility in what we can accomplish when we work together.

Quality

Deliver the highest quality legal advice and work product

We will consistently deliver top quality legal work on a timely basis. In every engagement, we will do whatever it takes to "get it right" and "right on time."

Be intensely responsive

Each of us will be fully available to our clients and one another. We will respond promptly to all client communications. We will communicate with our clients in a regular and robust manner.

Understand our clients' businesses and anticipate legal issues

We will apply what we learn about our clients to deliver top quality legal work and anticipate our clients' concerns.

Listen

Quality legal work requires that we listen to our clients' objectives for each engagement and do our best to achieve those objectives.

Value

Deliver value in every engagement

We will deliver excellent value and predictability about our legal fees. We will encourage innovative fee arrangements that provide for a "win-win."

Utilize thoughtful and collaborative teaming approaches

Our legal teams will be lean and motivated. Their talents, experience, and expertise will match the engagement.

Innovate

We will leverage technology and use innovative methods to improve our effectiveness and efficiency.

Purpose

Solving legal problems

Our purpose as a law firm is to serve our clients and to help them solve their legal problems with business and industry-focused solutions.

Making our communities better places

With purpose and dedication, we will build stronger and more just communities. Whenever possible, we will team with our clients to achieve this objective.

Supporting our Kilpatrick communities and colleagues

We understand the transformative impact our firm can have on our communities, our employees, and our clients. Our commitment to active citizenship enables all team members to drive positive change in the areas of community leadership, diversity and inclusion, philanthropy, pro bono, and volunteerism, while advancing firm values and fostering corporate, nonprofit, and school partnerships.



Hundreds of attorneys and staff committed thousands of hours to addressing blind spots and fostering inclusiveness



641,000+ hours dedicated to pro bono service since 2001



In 2021, more than 60 attorneys and staff supported legal clinics for distressed small businesses during the COVID-19 pandemic



KTS Employee Financial Support Fund is an independent 501(c)(3) nonprofit that supports colleagues experiencing hardship



8,620 students participated in educational programs with Kilpatrick volunteers in 2023



Recognized in 2021 for our diversity efforts by the legal department of a Fortune 100 company



182 young adults and job seekers participated in Kilpatrick career experience initiatives in 2023



Kilpatrick attorneys and staff volunteered 11,586 hours to support educational equity, economic opportunities, and resilient communities in 2023



Lawyers of Color Aspire Diversity Award winner



They're appropriately ranked at the top, reflecting the depth of the IP group at the firm as well as the complexity of the IP matters they are advising on."

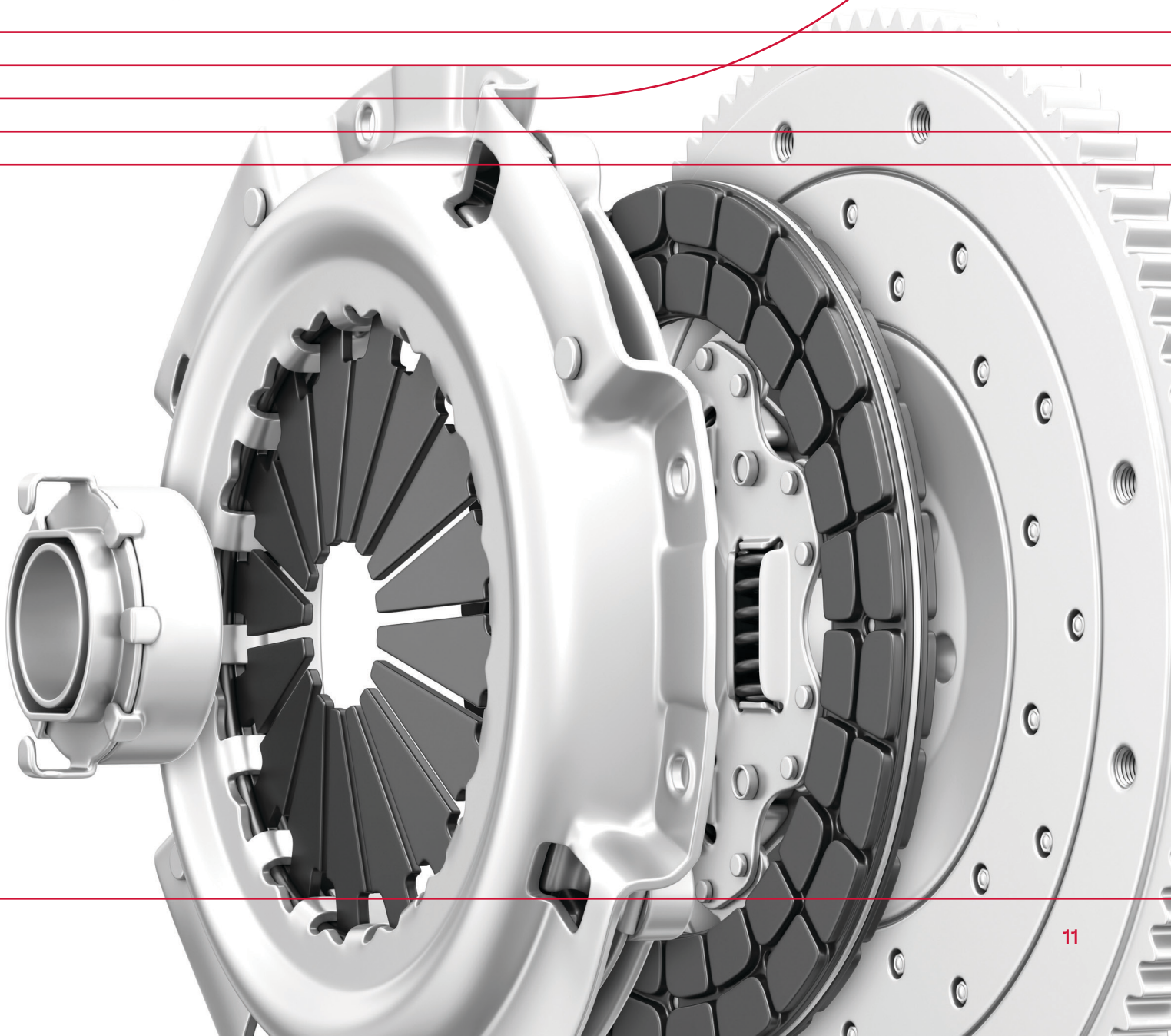

Anchorage
Atlanta
Augusta
Beijing
Charlotte
Chicago
Dallas
Denver
Houston
Los Angeles
New York
Phoenix
Raleigh
San Diego
San Francisco
Seattle
Shanghai
Silicon Valley
Stockholm
Tokyo
Walnut Creek
Washington D.C.
Winston-Salem

Kilpatrick

© 2024 Kilpatrick Townsend & Stockton LLP
ktslaw.com